

WiFi 2 Colors 2 Wires LED Strip Controller

Model No.: V2-S(WT)

2-wires CCT/Tuya APP cloud control/Voice control/Wireless remote control/Push Dim



Feature

- Only apply to 2-wires WW+CW LED strip.
- Tuya APP cloud control, support on/off, color temperature and brightness adjust, delay turn on/off light, timer run, scene and music play function.
- Voice control, support amazon ECHO and TmallGenie smart speaker.
- Match with RF 2.4G remote control optional.
- Each V2-S(WT) controller can also work as WiFi-RF converter, then use Tuya APP to control one or more RF CCT LED controller synchronously.
- Connect with external push switch to achieve on/off and 0-100% dimming function.
- Switch 3 levels color temperature(WW, NW, CW) in consecutive poweron sequence.
- Fade in and out effect selectable.

CE RoHS EMC LVD RED

Technical Parameters

Input and Output	
Input voltage	12-36VDC
Input current	10.1A
Output voltage	12-36VDC
Output current	10A
Output power	120-360W
Output type	Constant voltage

Environment	
Operation temperature	Ta: -30°C ~ +55°C
Case temperature (Max.)	Tc: +85°C
IP rating	IP20

Warranty and Protection	
Warranty	5 years
Protection	Reverse Polarity

Dimming data	
Input signal	Tuya APP + RF + Push Dim
Control distance	30m(Barrier-free space)
Dimming gray scale	256 levels
Dimming range	0-100%
Dimming curve	Linear
PWM Frequency	2000Hz

Safety and EMC	
EMC standard (EMC)	ETSI EN 301 489-1 V2.2.3 ETSI EN 301 489-17 V3.2.4
Safety standard(LVD)	EN 62368-1:2020+A11:2020
Radio Equipment(RED)	ETSI EN 300 328 V2.2.2
Certification	CE,EMC,LVD,RED

Mechanical Structures and Installations

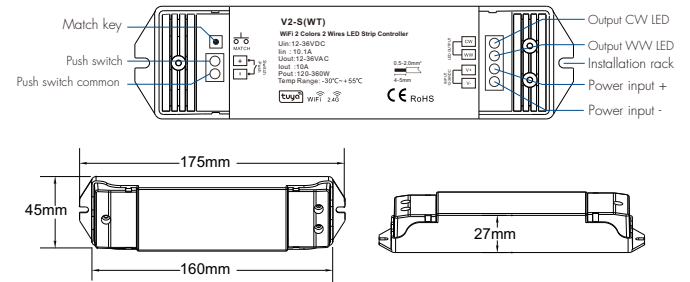

System wiring

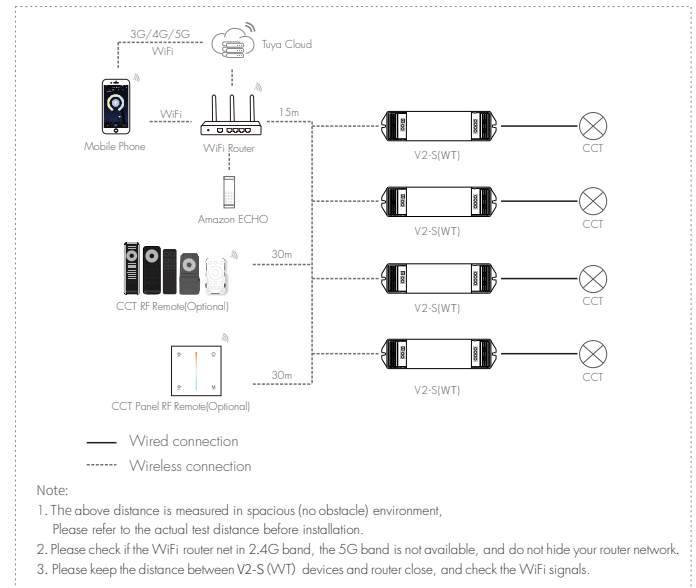

Wiring Diagram

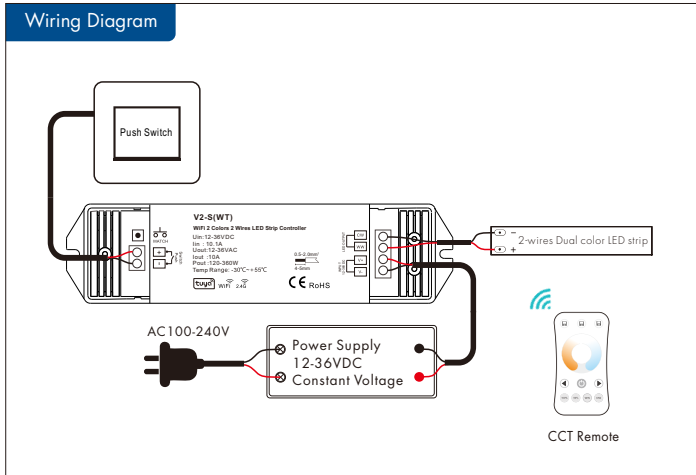

Note: 1. Switch off the power, then switch on power, repeat again.

Immediately short press match key 3 times, the light on/off time will change between 3s and 0.5s.

2. Continuous power off and an operation will change 3 levels color temperature (WWW, NW and CW) in sequence.

Push Dim

Click	ON/OFF
Double Click	Turn on at 100% or 10%(right light) and vice-versa
Long press(> 1s) from OFF	Color temperature UP/DOWN (turn off and turn on to return dimming)
Long press(> 1s) from ON	Dimming UP/DOWN

Tuya APP network connection

Press and hold Match key for 2s, or push twice Match key fastly:

Clear previous network connection, enter Smart config mode, the blue LED indicator flash fastly, the output LED will flash 10 times.

Press and hold Match key for 5s:

Clear previous network connection, enter AP config mode, the blue LED indicator flash slowly. If smart config failed, please try AP config.

Repeat power on and off for 5 consecutive times, also clear previous network connection, enter Smart config mode, the output LED will flash 10 times.

If Tuya APP network connection succeed, the blue LED indicator will stop flash, and in Tuya APP, you can find the CCT device.

Tuya APP interface

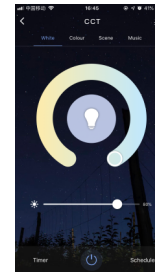

Touch color wheel to adjust color temperature.
Touch brightness slide to adjust brightness.

V2-S(WT) match remote control (Optional)

End user can choose the suitable match/delete ways. Two options are offered for selection:

Use the V2-S(WT)'s Match key

Match:
Short press match key of V2-S(WT), immediately press on/off key (single zone remote) or zone key (multiple zone remote) on the remote. The LED indicator fast flash a few times means match is successful.

Delete:
Press and hold match key of V2-S(WT) for 10s to delete all match,
The LED indicator fast flash a few times means all matched remotes were deleted.

Use Power Restart

Match:
Switch off the power of V2-S(WT), then switch on power, repeat again.
Immediately short press on/off key (single zone remote) or zone key (multiple zone remote) 3 times on the remote. The light blinks 3 times means match is successful.

Delete:
Switch off the power of V2-S(WT), then switch on power, repeat again.
Immediately short press on/off key (single zone remote) or zone key (multiple zone remote) 5 times on the remote. The light blinks 5 times means all matched remotes were deleted.

V2-S(WT) work as WiFi-RF converter to match RF CCT LED controller

End user can choose the suitable match/delete ways. Two options are offered for selection:

Use the controller's Match key

Match:
Short press match key of the controller, immediately press on/off key on the Tuya APP. The LED indicator fast flash a few times means match is successful.

Delete:
Press and hold match key of the controller for 5s, The LED indicator fast flash a few times means match was deleted.

Use Power Restart

Match:
Switch off the power of the controller, then switch on power, repeat again.
Immediately short press on/off key 3 times on the Tuya APP. The light blinks 3 times means match is successful.

Delete:
Switch off the power of the controller, then switch on power, repeat again.
Immediately short press on/off key 5 times on the Tuya APP. The light blinks 5 times means match was deleted.